

EFB Systems for Military Aircraft

Increased situational awareness for today's warfighter



Photo courtesy U.S. Air Force

Where ingenuity takes off™



UTC Aerospace Systems



SmartDisplay® G700

Aircraft Interface Device (AID)



Tablet Interface Module (TIM™)



Patent pending

EFB Systems for Military Aircraft

EFBs give pilots mobile access to real-time data and critical mission-related information with the swipe of a finger while also automating manual processes. Switching from paper-based manuals and navigation charts to EFBs improves situational awareness, mission effectiveness and efficiency, reduces fuel and operations cost, and will equip military aircraft for upcoming mandated FAA requirements.

UTC Aerospace Systems' EFBs offer enhanced functionality, broad capabilities and open architecture. They come complete with hardware, software and support services that allow flight crews and maintenance personnel to perform critical ground and in-flight data management tasks electronically.

Features

- The new SmartDisplay® G700 EFB includes customized cockpit display mounting hardware and installation kits
- USB and/or Bluetooth® connectivity to iOS or Windows® tablets via the Tablet Interface Module (TIM™)
- 1553 bus capability
- Night Vision Imaging System (NVIS)-compliant lighting components

Benefits

- Improved aircraft data collection and access
- Own-ship positioning for obstacle avoidance
- Tail-specific discrepancy log
- Loadmaster apps
- Faster response time for maintenance discrepancies
- Flight performance tracking for fuel optimization

Broad Compatibility

Our solutions operate applications in iOS and/or Windows® environments. Along with a core set of EFB and data management software applications, the UTC Aerospace Systems SmartDisplay® G700 EFB can be pre-loaded with a suite of customer-selected applications.

Connectivity and Two-Way Communications

Increased connectivity within the aircraft (pilot-to-pilot and pilot-to-loadmaster/other aircrew cross-talk/screen sharing) and outside the aircraft through messaging via SATCOM or datalink, depending on your preference or automated business rules. For instance, real-time long-range weather data can be received and sent to connected tablets for visual review by all aircrew as can own-ship position relative to flight path and taxi-way obstructions. In-flight mission changes can be made more efficiently and with less human error by utilizing connected avionics apps that will analyze current state (fuel, distance to objective, historical maintenance data) and recommend best routing. Apps such as eTechLog allow aircrew and maintenance an in-flight means of messaging mission critical equipment faults which can minimize turn-around times as well as accessing of historical tail-specific maintenance data for future aircrews. Data can also be sent to on-board printers.

Data link communications provides an efficient means to transmit real-time messages as a separate typing device is no longer necessary, while eTechLog allows pilots and maintenance two-way access to translate problems in-flight while also storing historical maintenance data.

Tablet-compatible EFB Systems

Our tablet EFB system enhances the functionality of tablet devices:

- Permits continuous in-flight full recharging of tablet
- Provides real-time avionics data visibility onto each tablet
- Two-way digital communication between the aircraft and other tablet EFB users
- Compatibility with a wide range of tablets (iOS and Windows®)
- Connectivity to multiple on-board devices
- Foundation for additional capabilities and future purpose-built EFB systems
- Field loadable for both embedded and hosted application software updates

Small Installation Footprint

Our tablet-EPB system has a small footprint so it can easily fit in cockpits and helps reduce aircraft weight and fuel cost (fuel efficiencies) by minimizing the amount of papers and manuals the flight crew is required to have onboard.

The tablet-compatible EFB system consists of two unique tablet interface modules (TIM™), an FAA/EASA-certified aircraft interface device (AID), and an installation kit. The TIM works with the AID allowing the user's tablet to perform as an EFB and access an array of key aircraft avionics data such as GPS position, ground speed and aircraft heading, to name just a few – something that has previously been unavailable to tablet EFB users.

Tablet EFB System Diagram

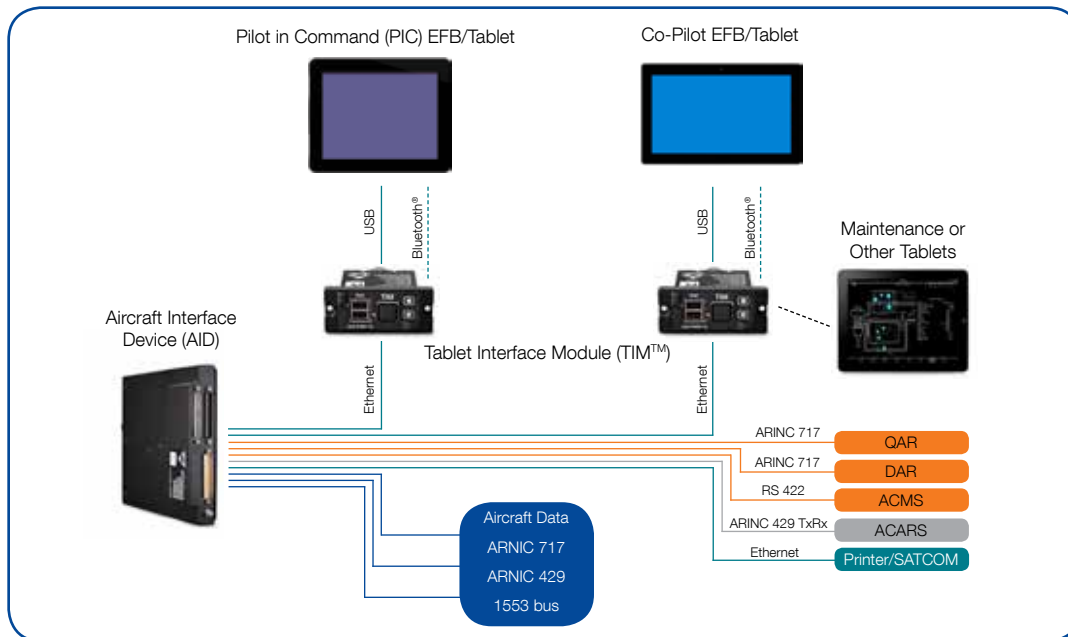

AID Connectivity

- | | |
|--|--------------------------------|
| • 1x +28VDC input power | • 1x RS 232 |
| • 3x 10/100 base-t Ethernet | • 16x GND/open discrete inputs |
| • 3x 10/100/1000 base-t Ethernet | • 4x GND/open discrete outputs |
| • 16x ARINC 429 bipolar receivers (2 receivers feature auto-detect for bipolar ARINC 717 data) | • 1x +28V/open discrete input |
| • 1x ARINC 717 hardware bi-phase receiver | • 1x 1553 bus capability |
| • 6x ARINC 429 transmitters | |
| • 1x RS 422/485 | |

Features

- Lightweight and low power solution (<2.5 lbs. and <25 watts)
- Backwards compatible with UTC Aerospace Systems first generation AID
- Field loadable software
- ARINC 834 STAP server
- Communicates with preferred SATCOM or ACARS providers
- 4GB RAM
- Qualified to DO-160G environments
- Solid state CFast SATA 32GB storage (w removable/ upgradable)

EFB Systems for Military Aircraft

Increased situational awareness for today's warfighter

Representative applications currently available:

- Aircraft moving map (own-ship positioning)
- Cross-talk between tablets
- eTechLog
- Communications data link
- Performance (TOLD, weight and balance)
- Electronic fight folder
- Weather
- NOTAM
- Aircraft health monitoring
- Document viewer
- Electronic charts

Benefits all areas of flight:

Flight Operations

- Integration potential with maintenance control
- Reduced paper document maintenance with improved revision control
- Improved aircraft data collection and access
- Faster response time for maintenance discrepancies

Ground Operations

- Tail-specific discrepancy log
- Loadmaster apps
- Own-ship positioning for obstacle avoidance

Maintenance

- Electronic record keeping
- Digital data entry and retrieval
- Reduced administration
- Faster response time for maintenance discrepancies

In-Flight

- Increased situational awareness
- Faster response time to mission changes
- Real-time flight performance and discrepancy tracking

For additional information:
14300 Judicial Road, Burnsville, MN 55306 U.S.A.
Tel: +1 952 892 4000
Toll-Free +1 844 UTAS EFB (+1 844 882 7332)
efb@utas.utc.com

This document does not contain any export controlled technical data.

utcaerospacesystemsEFB.com



Scan code for more information.

